

Rotator Kenpro KR400rc info

By G8MNY

(Updated Mar 08)

(8 Bit ASCII Graphics use code page 437 or 850)

This is a reliable rotator with manual L & R switches & servo motor driven heading 360° readout. It is similar to several ranges of models offered by different makers.

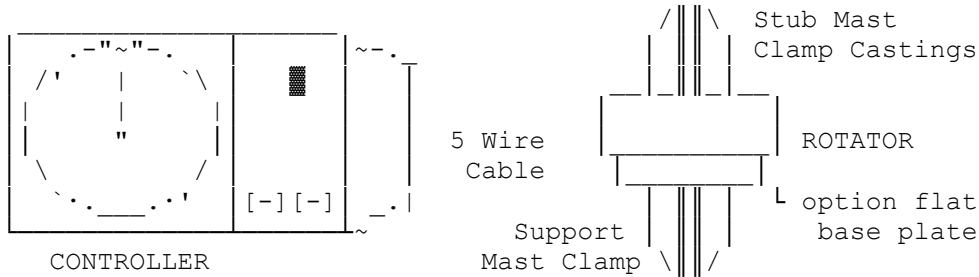

DIAGRAM

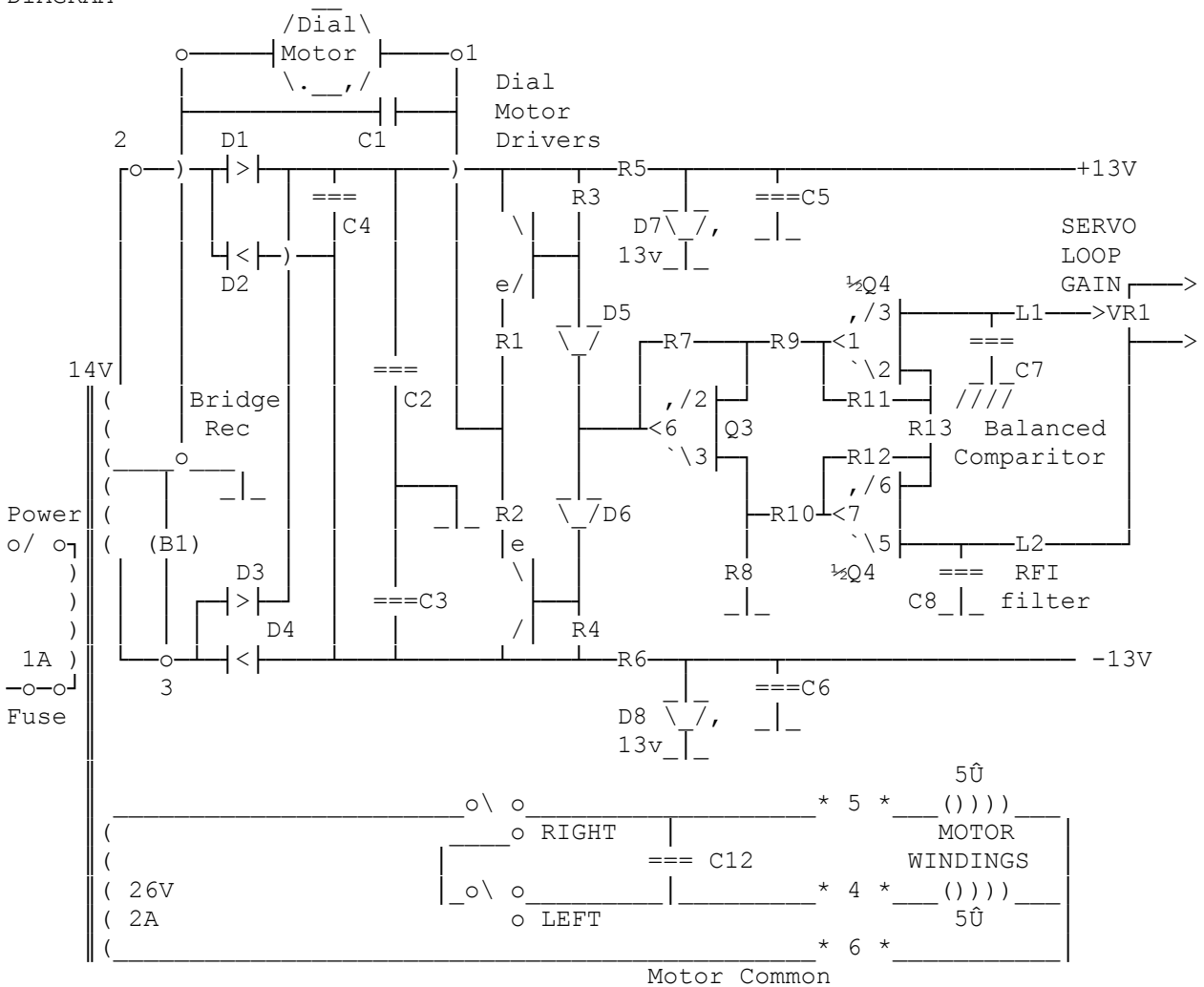

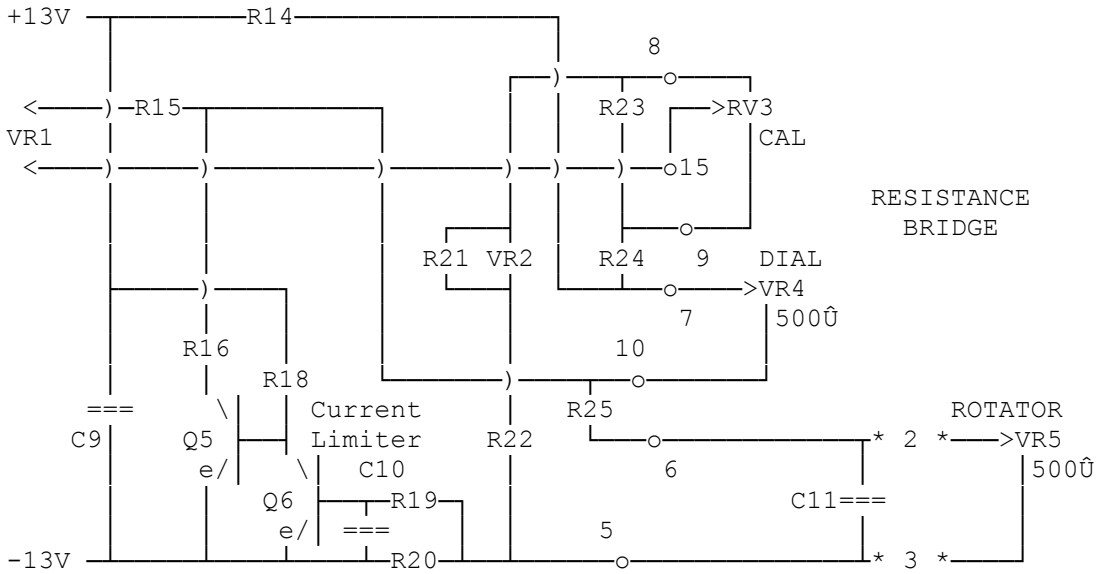

o = Internal PCB wiring points

* = External Terminals

COMPONENT

No	R	No	R	C	D	Q	VR	L	B
13	10k	1	220	10n	1N4002	2SC1815	20k	220uH	14V Bulb
14	1k	2	220	100u	1N4002	2SA1015	20k	220uH	
15	1k	3	10k	100u	1N4002	LM 741	10k		
16	390	4	10k	10n	1N4002	NMJ4558	500		
17	820	5	150	10n	1S1588	2SC1815	500		
18	47k	6	150	10n	1S1588	2SC1815			
19	33k	7	560k	10n	WZ130				
20	330	8	560k	10n	WZ130				
21	10k	9	10k	100u					
22	1k	10	10k	10n					
23	820	11	150k	10n					
24	5k6	12	150k	100u AC					
25	2								

Common faults..

I have seen on more than one occasion, a split in the plastic pinion on the DC dial motor. This causes the dial hunting as the display servo can't find the matching dial pot balance. The cure is to remove the motor carefully slide the pinion off. Roughen up the D shaped shaft, & using a resin glue, glue back on the pinion, maintaining pressure across the crack until the glue has hardened, then reassemble & test.

John G0JOP has had to replace the op-amp on his, I bet thsi was doe not static or mis-wire on pin 15 straight into the IC! Adding a few k ohm in series with the inductors L1 & L2 & 4 didoes on inputs to +/- rails may give protection!

A problem Bryan G6ODE found was a loose pinion gear on the motor shaft in the rotator.

Another problem Brian G8VPR mentions is the Rotator Pot going open circuit, so here is the circuit to help do tests...

MODIFICATIONS

I use mine for /P work & have done some mods...

- 1/ Add a 22 \hat{U} in series with the lamp, to improve lamp lifetime.
- 2/ Add an 8 \hat{U} 10W in series with motor common (*6*), to reduce super saturation of the motor. It can work ok with 18V with hardly any loss of torque, & for much longer before the motor catches fire.
- 3/ Add a 0.47 \hat{u} F 300V AC across the 240V mains I/P to Power Factor correct the permanent transformer load.
- 4/ Keep the pointer screw just loose enough for manual direction adjustment.

Why don't U send an interesting bul?

73 de John G8MNY @ GB7CIP