

Rotator 12V /P

By G8MNY

(Updated Jun 07)

(8 Bit ASCII Graphics use code page 437 or 850)

This I built from an old Army 24V motor gearbox system & 360° AC pot, bought new at rally many years ago. Although the same hardware may not be available other homebrew solutions may make this information useful.

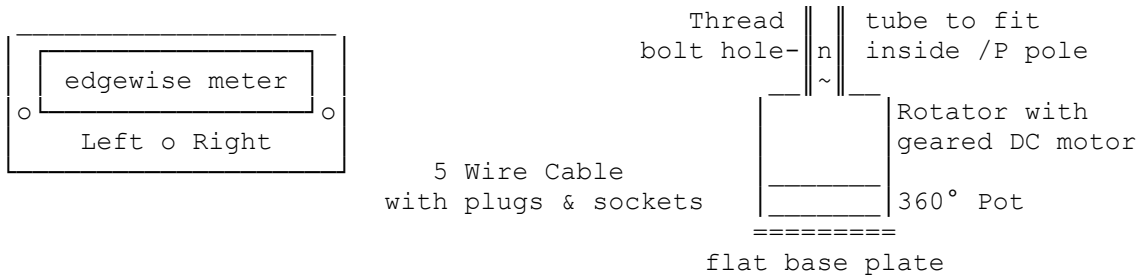

DIAGRAM

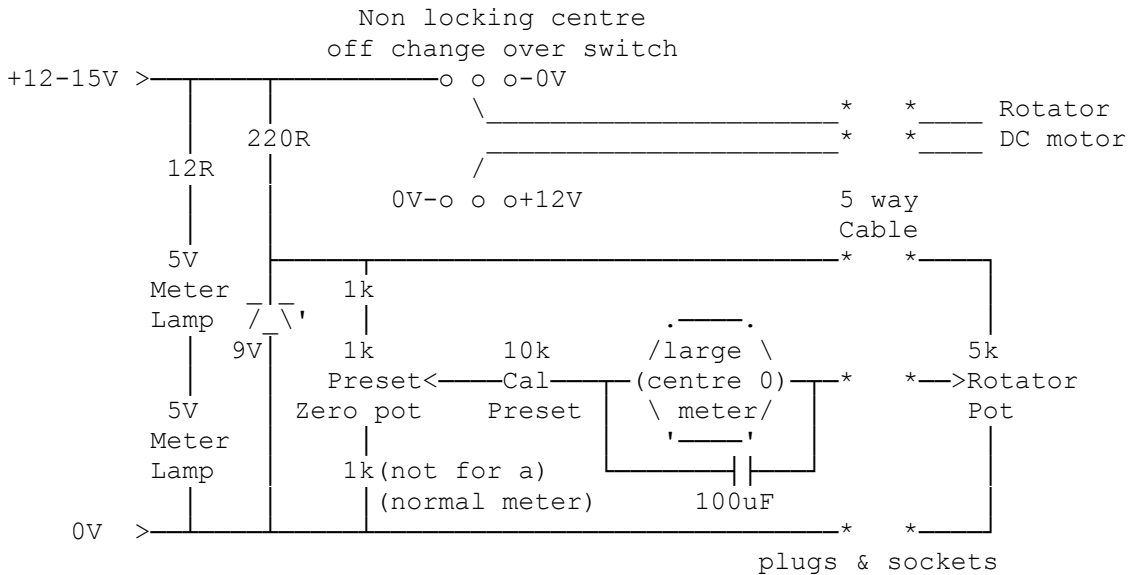

MOTOR CONTROL

The simple circuit uses just a non locking change over switch to power the under run low torque motor & gearbox, clockwise or anti-clockwise.

An under power rotator is useful for /P work as there is less chance of damaging fouled cables or guys etc. My rotator can be left stalled with no motor damage, as it only draws 50mA.

Note, you do not normally need speed for aerial rotation so a well geared down motor is best!

RF suppression of the motor may also be needed if you want to beam up on weak signals, try adding caps like 1n, u1, 1u etc. across brushes & to motor chassis as well as series chokes etc.

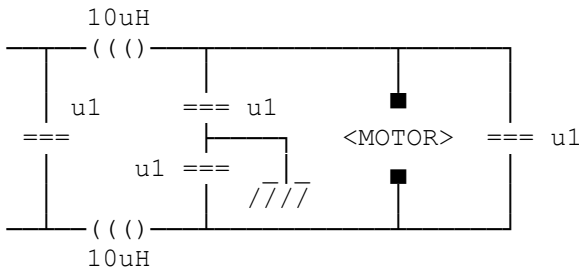

I do not earth the rotator through the control cable so there are no DC loops. Mast earth is provided by a clip on a flexible lead to a ground stake if needed.

POSITION INDICATION

My rotator pot was originally a 3 phase AC pot with 2 wipers & 3 pot taps, which was reconfigured to a straight forward 360° track pot with no stops.

The pot is powered by a shunt regulated 9V supply. A large sensitive centre zero meter is used (±1mA), but a non centre zero one can also be used.

The meter is damped by a 100uF so that a scratchy rotator pot does not cause wild readings. The zero preset pot sets the meter zero point (centre or side) & the cal preset pot sets the full scale indication.

If a rotator is used with stops then a geared down normal pot (e.g. 270°) can be used in the rotator & any unused track compensated for by this circuit.

My meter scale is marked.. as my rotator has no stops, so the needle swings from SOUTH to SOUTH marks quickly on overturn.

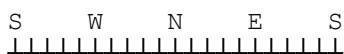

Physical calibration when portable is done by just lifting the rotator & mast turning whole thing & putting it back down (a brain teaser as to which direction!). Any tendency for the rotator to spin on the ground is solved either by a few tent pegs into grass, or placed on a sponge sheet if on tarmac.

MAST CONNECTION

My system for this rotator uses a hole in the mast pole that allows a screw to be put into a captured nut, in the inside of the smaller rotator tube.

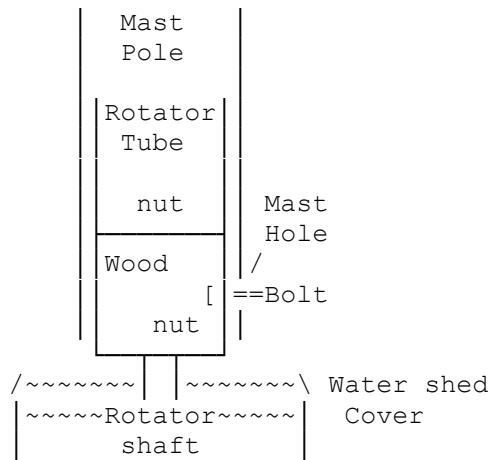

Why Don't U send an interesting Bul?

73 de John G8MNY @ GB7CIP