

USING BOTH METHODS

But if using both systems together, you get a poor correlation of heading between them, then the RF field being sampled is poor (distorted). This is because the aerial is turned through 90 degrees between the 2 measurement methods & you are seeing uneven RF field, so the 2 results cannot be trusted. Repeating the tests just a few metres or so away normally solve this. (away from overhead lines)

A label like this may be helpfull..

```

A          Doppler / | \      B
*  /_ ZL   Tone   / | \      *
   \ Null  Nulls \ | /
    
```

THE CIRCUIT

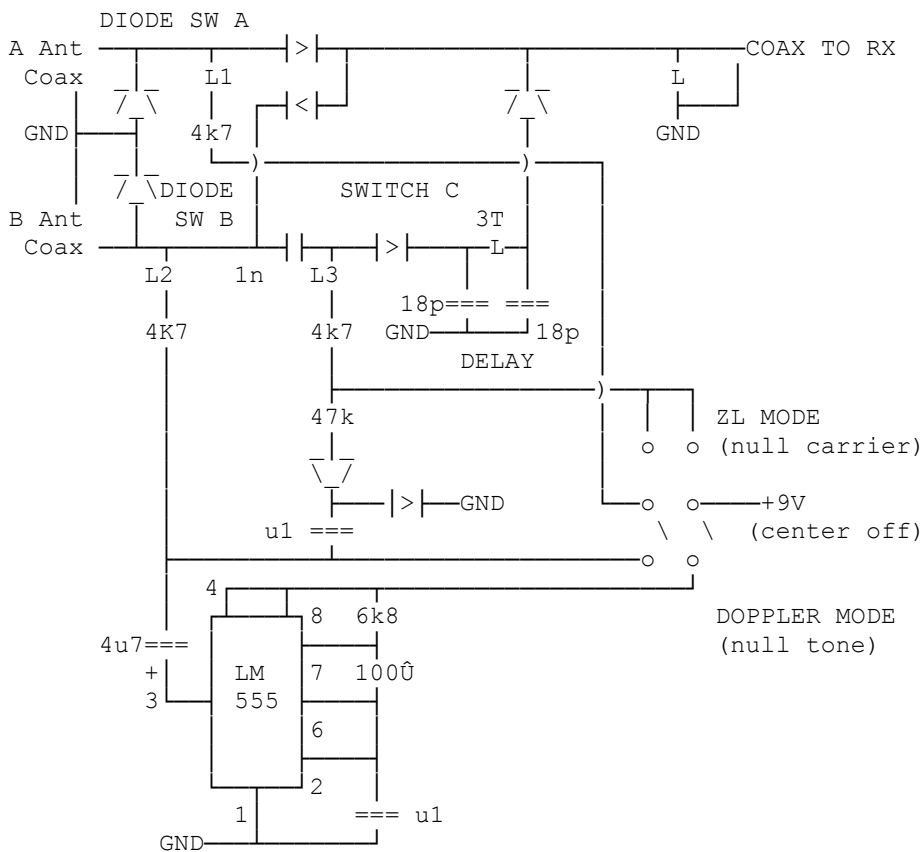

HOW THE CIRCUIT WORKS

The 2 aerial inputs each see a diode switch (A & B) using 1N4148 type diodes. The Ls are several turns on ferrite cores or beads, but if in series with 4K7 (L1-3) then they can be left out. Construction is on a PCB ground plain either by knife etching circuitry or ugly.

Aerial switch C is used to join the 2 aerials together, but with aerial B via a lumped delay line (or use a length of coax approx the same as the A-B gap) this L is about 3 turns 6mm dia & Cs used for this are set up to cause a signal null in one direction.

In ZL mode, diode switch B is off & switch C is on, passing the combined signal.

When the Mode switch is in Doppler mode, the control of the A & B diode switches is from a 555 square wave astable running at about 1KHz. With a diode pump circuit to completely bias off the C switch path.

In the off position there is no through path!

It is possible to Tx up to 2W into the unit without damage, but only a small amount of power passes through to the aerial!

IN USE

This aerial, FT290, & Map, have won a few of DF fox hunts, but has occasionally failed to find fox too, if the RF field is too distorted at some of the reading sites!

Why Don't U send an interesting bul?

73 de John, G8MNY @ GB7CIP