

1W at 531kHz MW Station System

From: G8MNY@GB7CIP.#32.GBR.EU

Hi Readers,

(Updated Oct 08)

For 6 years me & other hams have done six 1 month MW U.K. Restricted Service Licence broadcasts on 531kHz, (565m) which is more than 3x longer wavelength than top band, so you may like to know how we do it, especially as there is a 500kHz experimental UK ham band now.

Only vertical polarisation is used for MW broadcasting, as all domestic Rx are vertical (vertical car aerials & horizontal Rx ferrites rods), so horizontal radiating aerials are of no use. Also there is a severe restriction on RSL's, that limit the aerial height to only 20m at this frequency, so to get a good 1W MONOPOLE ERP is not at all simple.

This is how we did it...

THE AERIAL

We used a modified inverted L design that was suitable for our site, it has a 45° sloping vertical underneath the top section. This proves very effective with next to no horizontal polarization component.

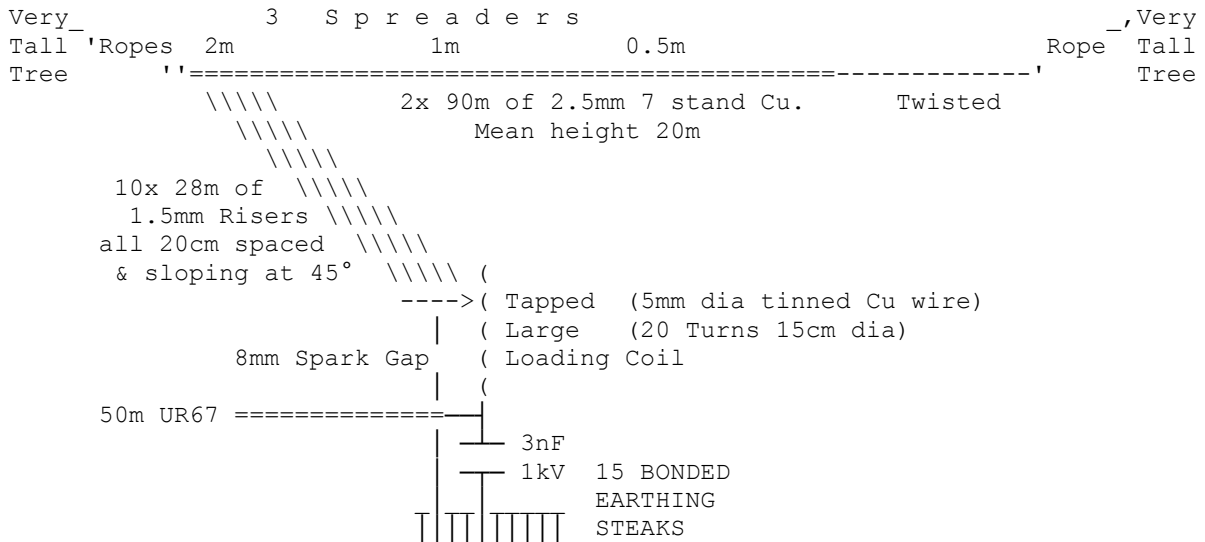

The 2 top wires are tied off in tall trees, really taught at 40kg tension. The 10 slopers use thinner 7 stranded wires to carry the current (as we had plenty of that wire available). We used 3 plastic pipes as spacer bars for the risers & 3 weight stabilised top spacer triangles. e.g.



TUNING & BANDWIDTH

Loading was done with a large tapped series L & with 3nF across the coax. The tapping point (copper strip with wires attached) is moved up, down & around the coil around until the return loss is > 35dB (SWR 1.04:1) is found. Then the tapping point is soldered on to the coil & retested. Normally there is some frequency offset of a few kHz to this process, but dressing the earth & aerial wire either side of the coil, fine tunes the aerial system to get this well centred graph...

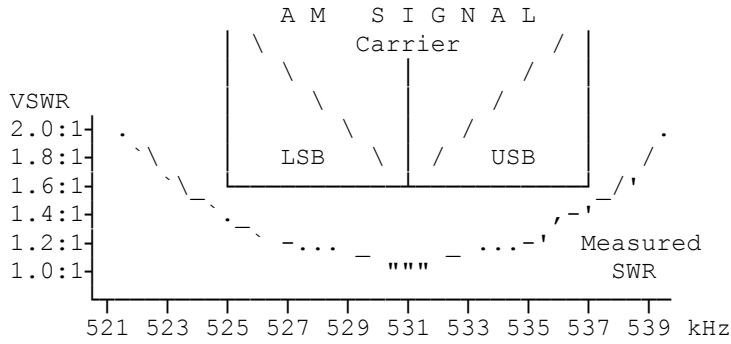

Tuning is very critical & only a narrow aerial bandwidth of $\pm 6\text{kHz}$ is possible, up to SWR of 1.5:1, but this is just about OK for Broadcast AM. The Tx AF system is quite flat 20Hz - 6kHz $\pm 1\text{dB}$ but $> -40\text{dB}$ @ 9kHz. Treble around 5-7kHz will produce phase modulated sidebands into this aerial, reducing the effective AM modulation depth!

EARTHING SYSTEM

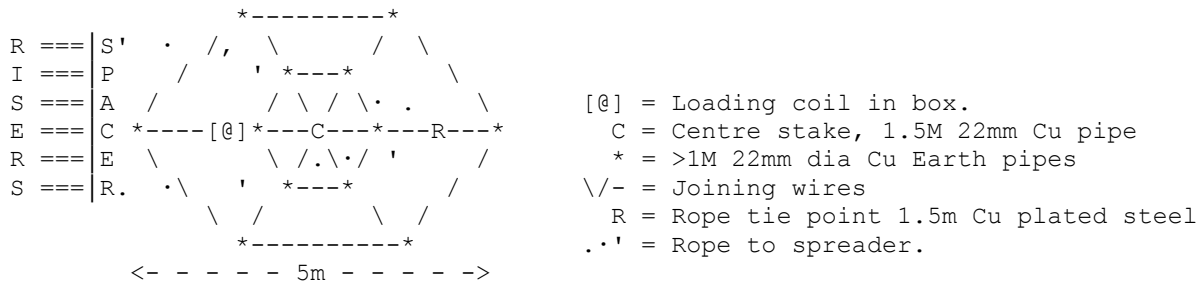

The earth uses 14 short copper pipes in 2 circles. We found that adding any more did not alter the aerial Z at all! Also adding 463ft counter poises had no detectable effect to the aerial Z either. I think this was due to the wet ground conditions 1m underfoot! Putting salt around the copper rods may have also help keep the earthing losses low in dry summers.

AERIAL EFFICIENCY & ERP

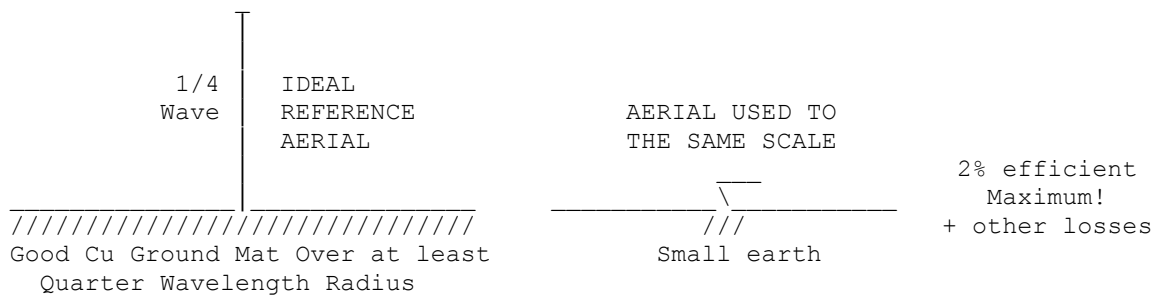

As the aerial height was only 1/7 of a 1/4 wave tall, the maximum aerial gain is in the order of 2% ($1/7 \times 1/7$), (-17dBi) as it was only base loaded. This figure is very close the radiation resistance method of calculation that gives 2.9%. But really the true aerial efficiency is all about ground surface resistance at the frequency over something like 10 wavelengths radius (5km) & not just the ground resistance at the Tx site!

FIELD STRENGTH MEASUREMENTS

As with all aeralis, there is near field (cube law) component not square law, & this should be much stronger with a tiny aerial like this, than with a full size ¼ or ½ wave aerial. This is due to the "transformer action" (like local CRT TV line timebase QRM).

N.B. A point source radiator has infinite electric & magnetic fields, but not at 90° & hence it has NO ERP.

This near field, has the effect of uncalibrating field strength measurements for ERP calculations locally (under 10 wavelengths), so local magnetic only field strength measurement method is not very accurate for estimates of the real ERP. The method is unless the -6dB/distance doubling can be shown to be true.

Also affecting the field strength at our site are large variations in the terrain type over the first few wavelengths (e.g. wet clay valley & 3 nearby dry chalky hills). These one would expect to affect the radiation resistance of free space (377Ω) near to the ground. Of course in free space at >10 wavelength away, the field strength measurement would be accurate for estimating ERP.

Both the Aerial & Tx system have been technically inspected by the regulator Ofcom & were all OK, & the system radiated the correct ERP when measured at a distant calibrated site.

THE TX

This is a large old DECCA transistor LW MCW aircraft navigation beacon Tx, pushed up to work on the edge of its frequency range at 531kHz, & it is only capable of about 400W PEP max, above that it was totally non linear. (The PA is OK for non linear CW @ 800W on LF to produce 10W peak ERP into short aeralis!)

So about 50W of AM carrier is needed for the 1W ERP. The broadcast modified Tx uses a temperature controlled Xtal Osc, to a low power AM exciter stage with diode clipping of the RF for give the AM, to a 1W tuned class A amp. This then feeds 6 large class B DC coupled amps pairs with NFB in push pull (36 TO3s in all), to an iron dust core O/P transformer. Across this is a large permeability tuned L (6 movable ferrite rods) that resonate the 24 caps across each PA transistor.

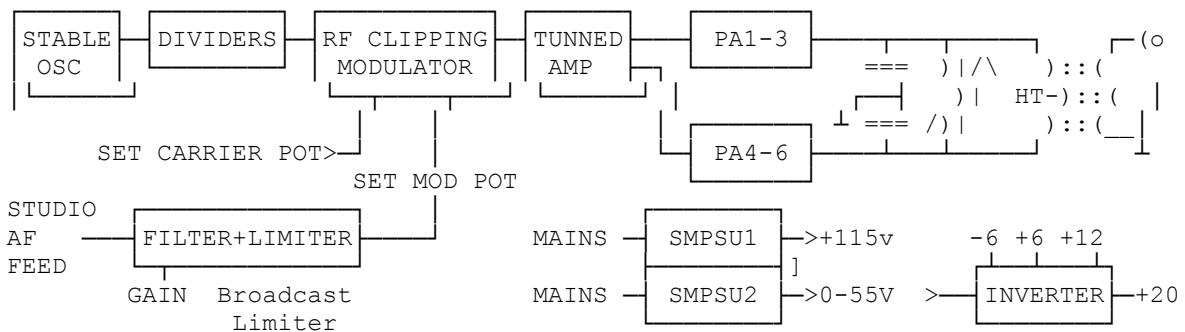

The original 2 HOT linear PSUs were 55V + 65V @ 4A, 12A peak (800W CW mode), are superseded now by two 2nd hand SMPSU ones that run cold, & reduce unwanted shack heating!

Although a very inefficient Tx design (10% at 50W on 531kHz) compared to high level AM mod, it does do very good bass & has linear phase down to a few Hz. This is because there is no modulation transformer or LF choke to give LF phase error. This is very important when used after an AM broadcast limiter that adds small amounts of near DC components, so not to muck up the modulation waveform.

Only efficient PWM system are as good.

HARMONICS

With this frequency the 2nd & 3rd harmonics are actually in band (MW)! With this Tx harmonics are > -60dBc & with the high Q of this aerial system, results in them being further suppressed to approx -100dBc. They actually can't be detected over sky noise 400m away from the aerial!

1W ERP RANGE @ 531kHz

Ground wave coverage is about 60-90 miles (100-150km) with a good normal Rx (only 10 miles 18km @ night due co. ch QRO QRM). With a comms Rx with RF quiet locations >400 miles (700km). e.g. we have Rx Dx reports from Finland, Italy, N.Scotland, Channel Isle etc. This seems extreme DX for a QRP MW station, but it would only be 1/3 of this range @ 1593kHz, & 1/9 of the coverage area, a point possibly missed by the licensing regulator! Aren't laws of physics wonderful.

However QRM from any SMPSU, PC Screens, TV timebase, Broadband phone cabling, & Fluorescent lamps, can easily wipe out a weak MW signal on this frequency.

Also see my bul on "AM Broadcast Radio Principles"

Why don't U send an interesting bul?

73 de John G8MNY @ GB7CIP