

23cm ATV Repeater GB3HV System

By G8MNY

(Updated Oct 08)

Here is a run down of this very complex repeater, now off air awaiting a new site. It was sited @ High Wycombe IO9100, that has grown & grown over many years, 1985 proposed 1987 on air.

It had ATV Rx on 3 bands, 2 with intercarrier sound & 1 band with a digital Rx. It also has 2 comms Rx channels as well. All of these control the repeater or output on the Analogue or Digital ATV Tx. As well as RF it recently had an expensive internet side with 1 way video steaming @ www.gb3hv.com (http://gb3vh.camstreams.com) where a few broadband visitors could see & hear live ATV. (activity peaks on Wednesday eve)

RX SIDE

4 Switched 90°

24cm Aerials @ 20m

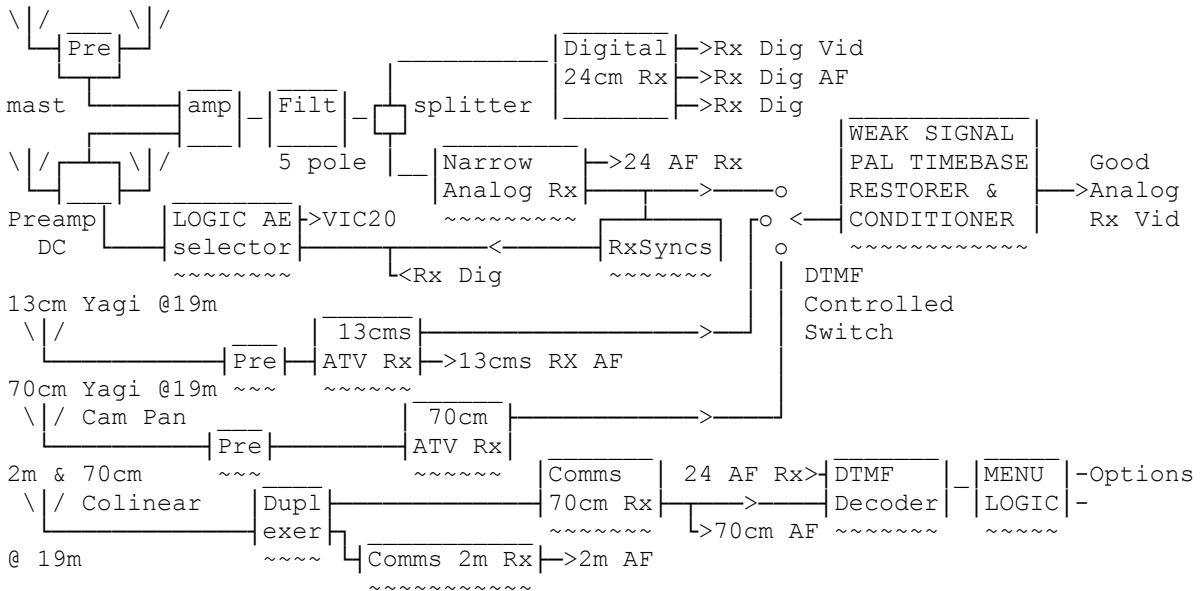

The four 24cm (6 loop & reflector) aerials are searched one at a time for the best picture by measuring the picture noise during the frame sync, this took several seconds if the radar is strong, as frame lock can be difficult. If you selected all 4 aerials or use an omni Rx aerial you are RF worse off by 6dB S/N + reflections!

The 1248MHz FM ATV Rx, had a radar video clipper in it & the video feeds a PAL conditioner that can handle very weak signals of just a few dB S/N. Software in the controlling old VIC20 also allows for DX signals by holding in repeat mode for up to 30 seconds if the signal is persistently fading.



The 13cm Rx system pointed at GB3BH, that can see 23cms ATV repeater GB3TV etc. So manually controlled forward linking was possible, but active onward link control was not possible.

The 2m & 70cm comms Rx could both be QSYed a few channels from DTMF menu.

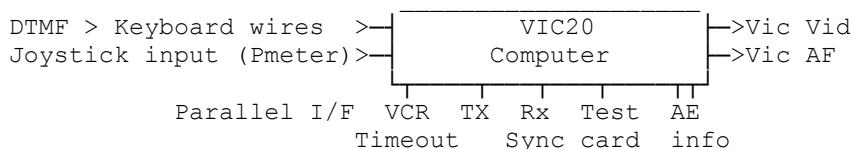

The very old but highly reliable VIC20 runs things (PCs crash, VIC 20 not!), & provides a carousel of 12 pages when in beacon mode, including control of the separate the testcard generator. The DTMF menus were all in hardware & menus seen were from the testcard generator multiple EPROM system. DTMF menu options have sound confirmation was by G8MNY's voice recorded in EPROM's.

An old V2000 format VCR had been wire up to record the 1st 10 mins of ATV activity, unless it is a SUNDAY RSGB news time, when the 10 min limit was suppressed.

All video sources were DTMF controlled from hardware menus. The video switcher had all inputs DC clamped so there was no DC thumps & Tx PLL off lock when switching sources.

| VIDEO SOURCES     |              | MATCHING AF1 SOUND SOURCE    | AF2       |
|-------------------|--------------|------------------------------|-----------|
| VIC20 Computer    | -o           | -o VIC20 ID + Rx Sync Tones  | 2m AF     |
| Test card gen     | -o <---Tx--> | -o VIC20 ID + Rx Sync Tones  | 2m AF     |
| Analog Rx (23)    | -o           | -o VIC20 ID + 24 AF Rx       | 2m AF     |
| " " (13BH)        | -o           | -o VIC20 ID + 13 AF Rx       | 2m AF     |
| " " (13FT)        | -o           | -o " " " " "                 | " "       |
| " " (70)          | -o           | -o VIC20 ID + 70cm AF        | 2m AF     |
| Digital 23cm Rx   | -o           | -o VIC20 ID + Dig Rx AF      | 2m AF     |
| V2000 VCR Replay  | -o           | -o VIC20 ID + VCR AF         | 2m AF     |
| Shack Camera      | -o           | -o VIC20 ID + Shack Mic      | 2m AF     |
| Security " "      | -o           | -o VIC20 BERP + Shack Mic    | Shack Mic |
| Mast Camera @ 20m | -o           | -o VIC20 ID + 70cm AF        | 2m AF     |
| Internet Video PC | -o           | -o VIC20 ID + Internet PC AF | 2m AF     |

TX SIDE

This was on 1308MHz which was the only frequency available 27km away from London Heathrow 530MW ERP 4 channel Radar (Primary User).

4 90° 23cms  
Aerials @ 22m

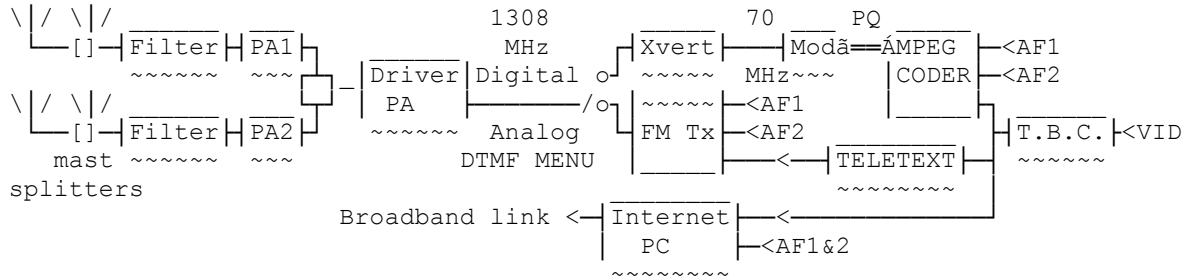

Two FET PAs were used, & were linear enough to handle QPSK digital Tx at only a couple of dB down on the saturated FM output. As the MPEG coder can only encode full spec video a Time Base Corrector is used to clean up all the Tx sources to full TV spec. The encoder generates P & Q data streams that drove the 70MHz QPSK modulator, its output was transverted to 1308MHz. As the main mode is FM, users had to DTMF to digital mode, which lasts until 1 or 2 of 15 min testcard idents were done.

Only the analog Tx system could handle the 7Mb/s 100 page Teletext signal so that is inserted into that path only. Two sound carriers were used, a HiFi one @ 6MHz @ -17dBc & a comms quality one @ 5.5MHz @ -20dBc (not Sat Rx freq). As there was potential with a 1308MHz FM Tx with 6MHz sub-carrier to generate significant -12MHz (1296MHz) noise, a clever 2nd harmonic subcarrier (both for 5.5 & 6MHz) phasing system is introduced to null out much of the 1296MHz products, this was in addition to the 3 pole Tx filters.

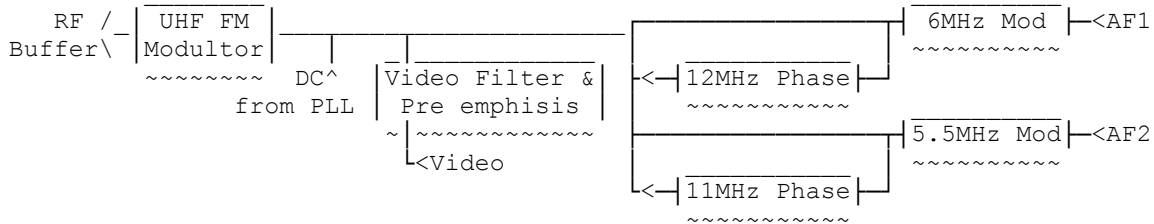

Why Don't U send an interesting bul?

73 De John, G8MNY @ GB7CIP