

HF ATU and SWR Bridge VC300LP QT-1

From: G8MNY@GB7CIP.#32.GBR.EU
 To : TECH@WW

By G8MNY

(Updated May 08)

(8 Bit ASCII Graphics use code page 437 or 850)

I have reverse engineered this from an old VECTRONICS ATU Model VC300LP(PreMFJ) which seems the same as the VC-300DPL & also the Canadian AEA's QT-1 model but that one has only a simple 12 tap switched inductor.

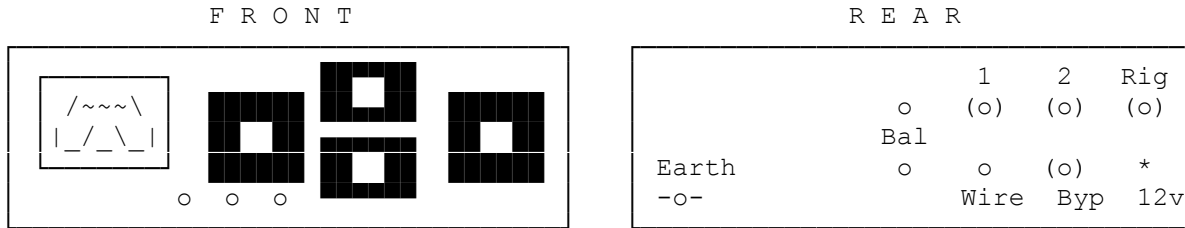

It is a small cheaply made unit, but it does have many advantages as there is a lot in the one box.

Aerial Tuning Units are also called Aerial Matching Units, but the best aerial is one that is already tuned by design (cutting) & a good match (tap point)!

BLOCK DIAGRAM

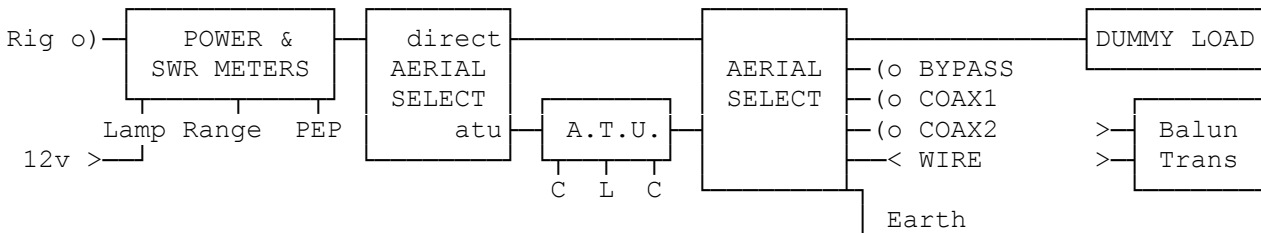

FEATURES

- 8 Position Switch:- 4 Aerial Choices, Bypass, Coax 1, Coax 2, & Wire.
- 4 Option with ATU:- 3 Aerials & 1 Dummy load for pre tuning.
- 300W max. (150W @ 1.8MHz) SSB ATU Rating. 4:1 Max SWR @ 300W.
- ATU is "T" Type, 48 tapped Inductor, 2 tuning Caps (1000V rating).
- 30W & 300W Forward scale cross needle power meter.
- 6W & 60W Reverse power scales, for increased SWR sensitivity.
- Average & PEP meter modes. (PEP poor design)
- Built in dummy Load (50W cont, 10 seconds rated @ 300W ?).
- 4:1 BALUN option for balanced aerials (link from wire ant)
- 12V Meter scale Lamp & on/off switch.
- Size 10.2 x 9.4 x 3.5" or 257 x 85 x 197mm, weight 3.4LBS

CIRCUIT

The SWR bridge is quite conventional. The PEP mode with large 47uF is not effective, an active system is really needed for true PEP!

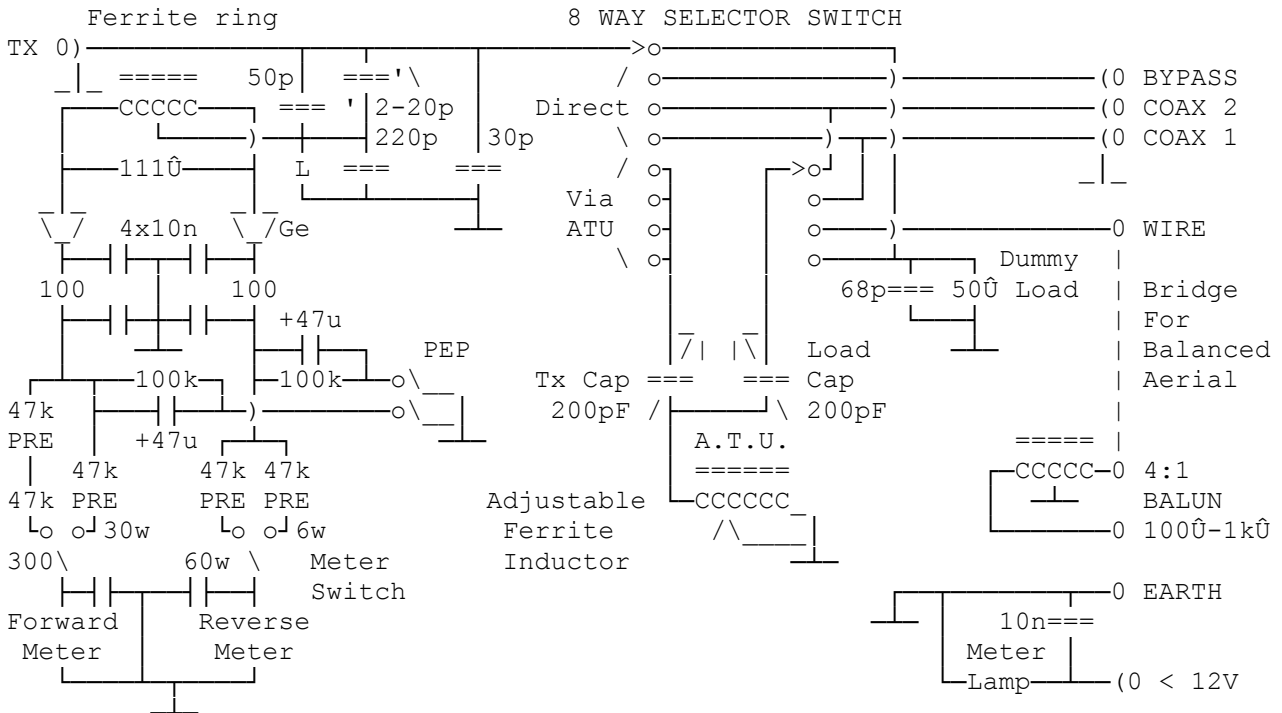

CONSTRUCTION

Uses thick 2 part aluminium case, thick open wire for all internal connections & the impedance is then tamed by the addition of extra caps to ground. (e.g. 68pF across the internal load & 30pF after the SWR Bridge.) One PCB provides for all the component mounting except the main switch, ATU components, & dummy load. All earths are to the local chassis with locking washers.

TUNING UP

The best tuning method is to use the ATU into the dummy load first at low power (between 10 & 30W) & pre-tune it, set the ATU with both Cs about 50% & adjust the L tap for initial minimum SWR, then tweak the Cs for perfect 1:1 match. Then switch to the aerial & re-tweak the Cs for 1:1. This is kindest for the ATU & also for minimum QRM to others. Very briefly re-tweaking at full power may be an advantage as the meter reads more accurately with more power.

Both the outputs select switch & the ATU variable L, should not be operated with any great power flowing as the contacts could be damaged with arcing!

IN USE

The Ferrite Balun & ATU Tapped Inductor can suffer saturation losses if inappropriately used. But in general there is much less loss with ferrite cored devices, than the much bigger air spaced equivalents, as there is many times less copper wire needed & associates copper loss. Typically loss is only 5% (0.2dB) of the power @ 100W (100 in 95 out) on any band at any SWR which is quite low for a combined ATU & SWR bridge.

If the random wire aerial won't tune up to give 1:1 SWR the try a different length (shorter by a metre or so).

The "T" type ATU is easy to use, but is not so good at removing Tx harmonics as the \hat{O} (pi) type. But it does an excellent job of protecting the Rx from strong signals on lower bands (e.g. removing Broadcast signals as it is $>-18\text{dB}$ for each frequency halving.)

MODS

- 1/ The black knobs on black background are not visible, I have painted white lines on mine, so I can easily see their direction.
- 2/ I blackened the dummy load & the aly plate it is on, with spray mat black, & used heat compound between that & box bottom, to improve load rating (2x).
- 3/ The cross needle meter needed damping as it is very swingy, see my Meter damping/speed up bulletin for corrective action.

Why don't U send an interesting bul?

73 De John, G8MNY @ GB7CIP